

**Advanced Products and Solutions for
Battery
Manufacturing**



Develop and Manufacture Next Generation Batteries

Cutting Edge Technologies for Advanced Applications Across Multiple Industries



Battery Tab Welding

- Laser cleaning
- Laser welding
- Resistance welding
- Micro TIG welding



Battery Modules and Packs

- Laser and resistance welding of current collector to busbars
- Laser and resistance welding of tabs

Industries

- Medical
- Automotive
- Consumer electronics
- Wearables
- Solar
- Aerospace



Battery Can

- Laser welding lids to cans
- Diaphragm assembly
- Pressure vent



Electrode Cutting

- Laser cutting leads



Part Identification

- Serial numbers
- Barcodes
- 2D codes



Terminal Welding

- Wire compacting
- Laser cleaning
- Laser, Resistance and MicroTIG welding



Laser Cleaning

- Surface roughening
- Remove dirt, grime, impurities
- Better weld results



Internal Connections

- Laser welding
- Resistance welding

Batteries & Materials

For each type of battery manufactured, AMADA WELD TECH offers a production solution: resistance welding, laser welding, laser marking, laser cutting and micro TIG welding. We have in-depth knowledge of, and experience with each category and application, including welding internal connections, battery tab welding, can sealing, marking for identification and more. Recent advances have been made in laser welding of dissimilar metals and battery tab design optimization. Our in-house applications labs enable proven processes to be delivered with optimized systems.

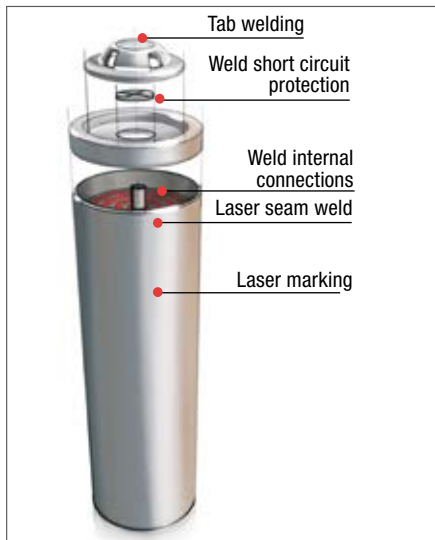

Cylindrical

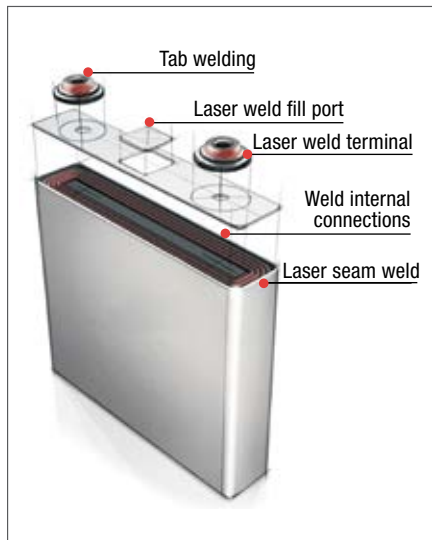

Prismatic

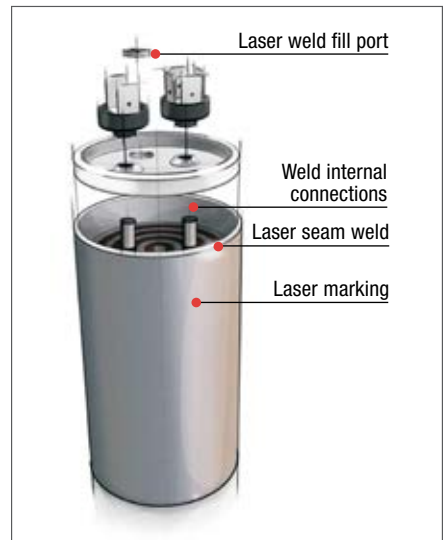

Ultracapacitor

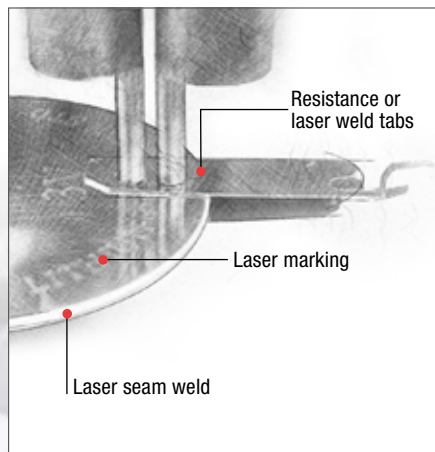

Coin

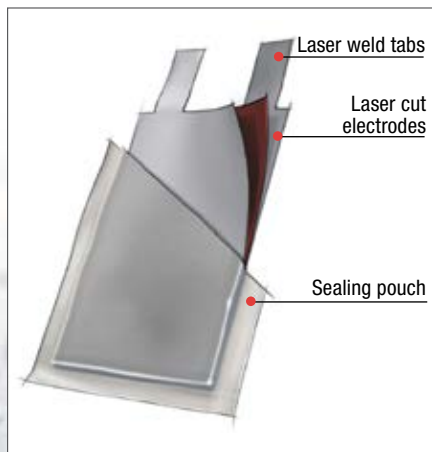

Pouch

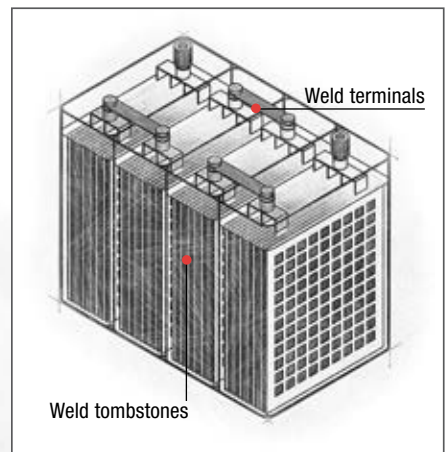

Lead Acid



Battery and Battery Pack Designs

Today's batteries and battery packs need to be more efficient, to charge faster, and those charges need to last longer. In order to meet these demands, battery tabs are thicker, more conductive, and, rather than using pure nickel, manufacturers are starting to utilize materials made of copper sandwiched by stainless steel and nickel up to 0.5mm (0.020") thick, or changing to more conductive materials like bare copper and aluminum.

**Battery Tab Welding • Tab to Terminal Welding • Battery Can Sealing
Dissimilar Metal Joining • Lead Acid Battery Welding • Wire Compacting**



Tab weld



Dissimilar metal welding



Spiral welding battery tab

AMADA WELD TECH has over 50 years of experience helping customers improve their battery welding applications including material selection, tab design (projections, slots), part fit up/tooling, and laser cleaning. We have developed innovative solutions like cascade welding to address multiple locations within battery cells - including clamping multiple tombstone locations. In addition, we have developed laser welding solutions for joining dissimilar materials - including spiral welding - to enhance material options and weld joint integrity.

In addition, because we manufacture a breadth of joining technology products, we can present an unbiased solution to meet your manufacturing and budget requirements.



Reliable Connections for Higher Current, Increased Reliability and Improved Performance

As world electrification continues to grow, so will the demand for high performance batteries to power it. The challenges encountered in bringing these batteries to market include the demand for reduced weight, expanded life, faster charge times and lower costs. Translated into manufacturing goals, the batteries need to possess higher capacity with negligible energy loss, higher current carrying capacity for charging, and be made of light-weight, lower cost materials. Since the market is so rapidly expanding, there are additional manufacturing challenges, including the demand for higher throughput and quality. Some of these goals can be achieved by improved cell chemistries and battery pack design, but others can be improved only by considering the joint quality between the batteries and the current collectors. That's where AMADA WELD TECH comes in!

**Battery Tab to Cell Welding • Tab to Terminal Welding • Dissimilar Metal Joining
Tab/Current Collector to Busbar Battery Can Sealing • Lead Acid Battery Welding**



Battery modules and packs



Prismatic battery cans



Battery tabs

AMADA WELD TECH offers a range of welding technology solutions for battery manufacturing including resistance welding, laser welding and micro TIG welding. As the materials and thicknesses continue to change, the right technical solution to join the materials also may change. With wide ranging expertise, AMADA WELD TECH recommends the best technical solution to join your new challenges - and helps to develop a robust production solution.



Part Identification: Global Tracking & Tracing

Today's battery manufacturers know that part identification and traceability are critical for success. Most batteries need to be marked with both human and machine readable characters which may be alphanumeric (serial numbers, etc.), datamatrix codes, or both in order to facilitate branding and identification. Lasers are uniquely suited for this application as they are a direct part marking method capable of delivering precise energy to parts with a minimal heat affected zone resulting in high throughput and image quality, thereby eliminating rework and post-processing steps.

High Contrast Marks • High Throughput • Traceability • Ensuring Quality



Product identification - Alpha numeric text strings



2D data matrices



Graphics and logos for safety and compliance information

AMADA WELD TECH provides laser engines for automation, desktop and floor standing Class I systems for low volume production and R&D processes, and fully automated custom systems for higher volume production with consistent product quality. Every laser is delivered with a process developed by our experienced applications engineers, informed by your requirements. Enhance your productivity with: barcode job loading, tie to ERP/MRP, industry 4.0 ready, and vision and fixtureless marking.



Laser Cutting Thin Foil Battery Electrodes

In 1995, the pouch cell surprised the battery world with a radical new design. Rather than using a metallic cylinder and glass-to-metal electrical feed through for insulation, conductive foil tabs welded to the electrode and sealed to the pouch carry the positive and negative terminals to the outside. These pouch cells offer a simple, flexible and lightweight solution to battery design which makes efficient use of space and achieves 90-95% packaging efficiency, the highest among battery packs. Elimination of the metal enclosure also reduces weight. Laser cutting is a fast, clean way to cut these electrodes.

Pouch Cells



Laser cut electrodes



Weld pouch cell tabs

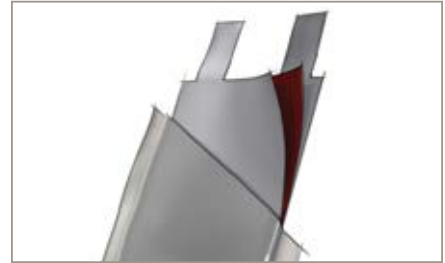

Welding anode and cathode foil material

AMADA WELD TECH provides technology solutions to the world's leading battery manufacturers according to the customer's unique application, manufacturing facility, and budget, including laser cutting systems configured for single operator, semi-automated or automated production.



Surface Cleaning of Anode and Cathode Ensure High Quality Welds

Cleaning of the battery anode and cathode can greatly improve success of the welding process by creating a pristine, repeatable surface for joining. Whether using resistance welding, laser welding, or another joining method, laser cleaning *before* welding can significantly improve the process and quality.

Laser cleaning works by focusing a laser onto a substrate to remove material on its surface. The amount of material removed depends on the intensity, pulse width and wavelength of the laser, as well as the material itself which absorbs the laser light and breaks down the chemical bonds in the area. It can be achieved with either a pulsed nanosecond (fiber) laser or a continuous wave laser, although the former is more commonly used due to the high level of laser intensity.

Fast • Safe • Cost-effective

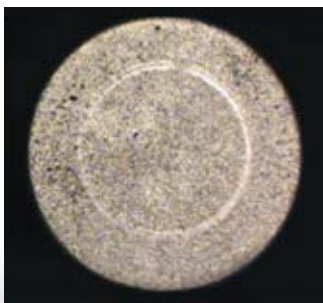

Image of battery cell surface before ablation

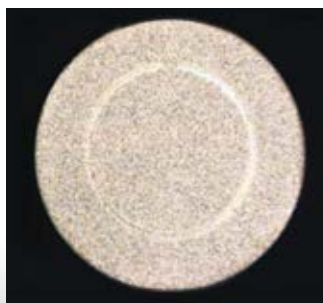
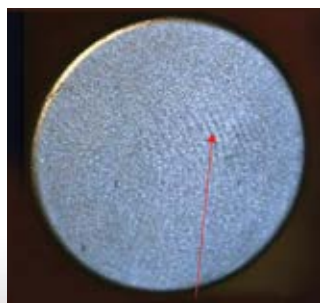
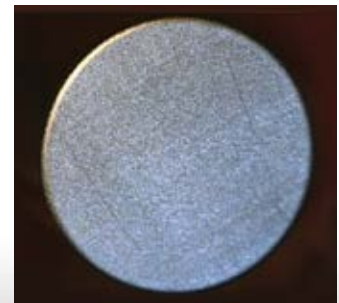

Image of same surface after ablation



Before - note fingerprint



After - clean and no fingerprint

AMADA WELD TECH offers a range of fiber lasers and workstations for laser cleaning applications. The exact products selected will depend on many factors including materials, size of parts, and factory space.

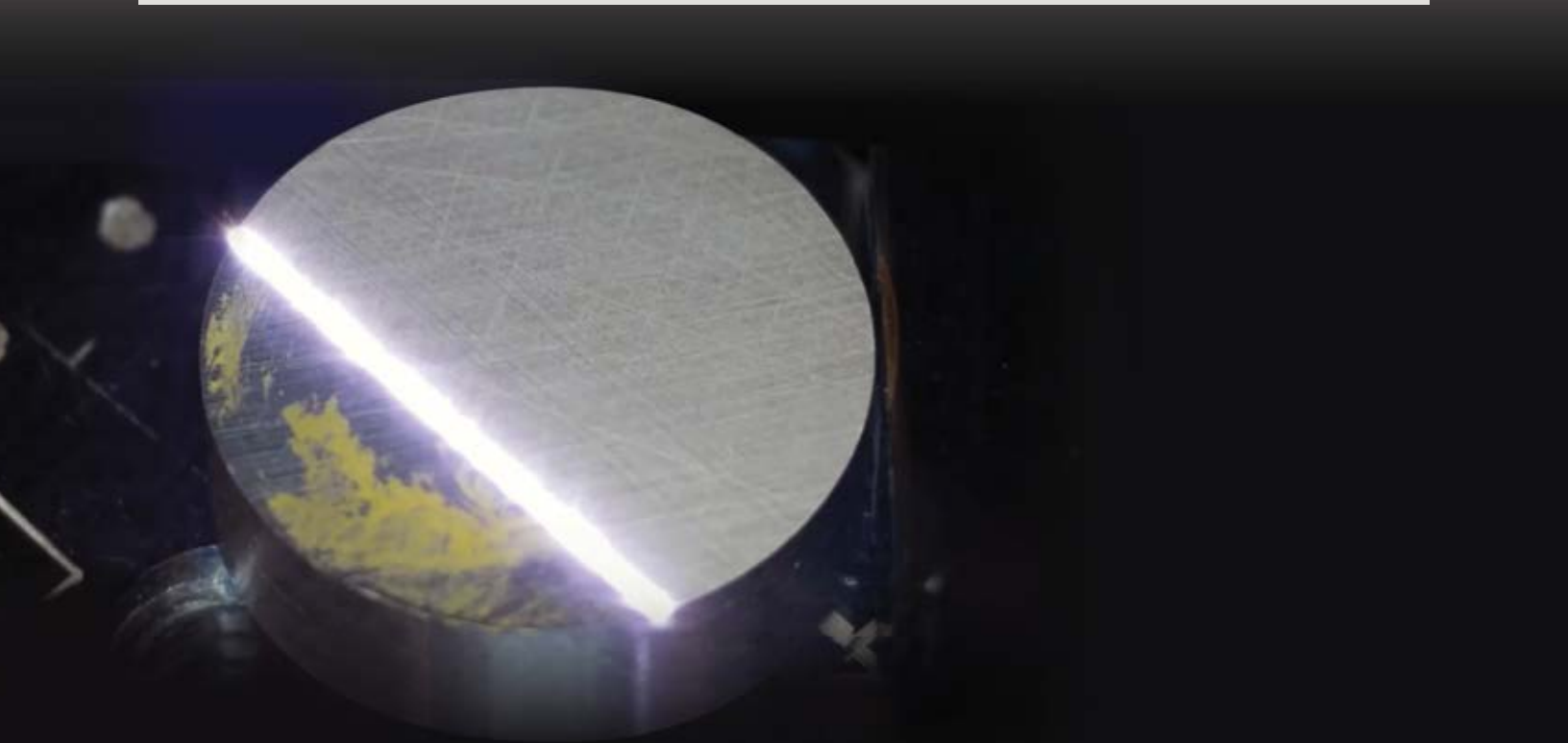

Ensuring Manufacturing Success with Process Monitoring

Product failure. Upset customers. Product on stop shipment. For the process manufacturing engineer, it's a worst-case scenario. When this situation occurs, it requires swift attention and accurate resolution: do you know the fundamental underlying issue? Can you calmly and expertly identify the source of the problem and what to do to get back on track? This is where process monitoring comes in. By observing and measuring the process, it is possible to discern good from bad product and, when bad occurs, specify defect signatures. In fact, process monitoring can help manufacturers avoid this situation altogether.

Monitor resistance welding parameters like weld current, voltage drop across the electrodes, workpiece expansion and deformation, electrode force, electrode movement (displacement) and more. For laser processes, detect and record thermal signals and set an envelope (min/max) to determine good and bad welds by identifying errors such as gaps between parts, missing parts, over-penetration, incorrect focus, and cover gas absence.

The monitor data can also be used to develop better manual or automated workstations that can avoid weld inconsistencies. Plus, data collected with monitors can provide value *after* a product is sold in case of a recall or similar situation, as weld data can be correlated with serial numbers.

Improve Quality • Reduce Downtime • Reduce Scrap

AMADA WELD TECH offers real-time process monitors for **laser welding, resistance welding, micro TIG welding and hot bar reflow soldering**. These stand-alone monitors are invaluable tools for product development, improving quality and throughput in production, and storing data for traceability.



Products for Manufacturing

Since 1948, AMADA WELD TECH has worked to achieve one goal: to solve customers' manufacturing challenges. Knowing there is no one solution that fits all, we strive to provide customers with innovative and reliable manufacturing technology solutions in an effort to be their single source provider.

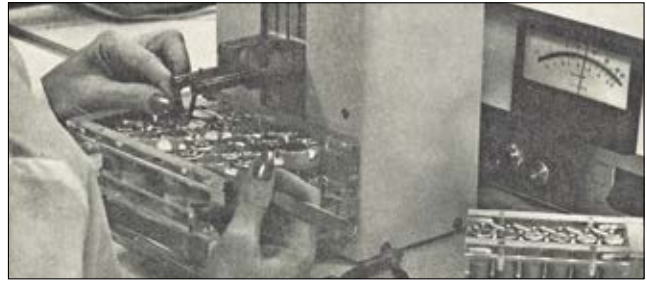

Battery welding ca. 1970

AMADA WELD TECH's broad range of core technologies - provided as benchtop single operator units, semi-automated workstations or fully automated systems - means that you will get exactly the right solution for your specific application depending on factors like materials, part accessibility, and desired throughput.

Core Technologies

Resistance Welding

Laser Welding

Laser Micro Machining

Weld Monitoring

Laser Marking

Integrated Systems

Micro TIG Welding

Laser Cutting

Gloveboxes

Reflow Soldering

Laser Soldering

Hermetic Sealing



Our Philosophy: Define - Design - Deliver

Developing a unique solution geared for advanced manufacturing is complicated. Our approach? Define-Design-Deliver. This methodology helps us design the ideal system to meet your manufacturing needs and budget while maximizing your equipment investment ROI and meeting your production goals.



Process Assessment

- Determine part usage and success
- Optimize part designs
- Select material

Sample Qualification

- Process sample parts
- Determine optimal production settings



Equipment Specification

- Meets production, quality, and budget criteria
- Product flow
- Customer requirements

Product Assembly

- Engineer oversees project
- Work with customer & technicians



Test and Verification

- Rigorous testing
- System acceptance
- Customer directed

Installation and Support

- Install system
- Verify functionality
- Training



Value Added Services

Training

We offer application support and process development services at our Technical Center in Monrovia, California or on-site at your facility. These services can be tailored to meet your specific needs and may include hands-on equipment training.

Topics

- Technology Fundamentals
- Developing Process Success
- Equipment Troubleshooting

Location Options

- On-demand Webinars
- Live Webinars with Q&A
- Factory Hands-on
- On-site Training (specific to your equipment)



Around the Clock Service Support to Minimize Downtime

Inevitably something may go wrong. This can be caused by a multitude of reasons, but ultimately the longer that the product is out of order, the more costs are incurred.

We are there when you need us.

24/7 Field Service

- +1-866-751-7378
- service@amadaweldtech.com

Our Commitment

Dedicated Development Resources

- **Core Technologies** - Laser Welding, Resistance Welding, Laser Marking, Laser Micro Machining, Laser Tube Cutting, Micro TIG Welding, Reflow Soldering, Hermetic Seam Sealing
- **3 Lab Locations** - Los Angeles, CA, Detroit, MI, and High Point, NC
- **Skilled Engineers**- 10 full-time application engineers and technicians
- **Facilities** - 10 state-of-the-art application labs for all core technologies
- **Range of Lasers** - CW and QCW fiber lasers, diode-pumped solid-state (DPSS), Nd:YAG lasers, picosecond lasers and femtosecond lasers
- **Range of Beam Delivery Options** - Fixed, 2D and 3D galvo-scanning, wobble head, trepanning head
- **Range of Resistance Welding Power Supplies** - Linear DC, High Frequency, Cap Discharge, and AC Resistance Spot Welding Controls (5 A – 100,000 A)
- **4 and 5 Axis Laser Welding Workstations**
- **Gloveboxes for Processing in an Inert Atmosphere**



Free Sample Evaluation

Not sure your application is feasible? Want to know which technology is best suited to your process? AMADA WELD TECH offers FREE sample evaluations. Contact us to get started today!

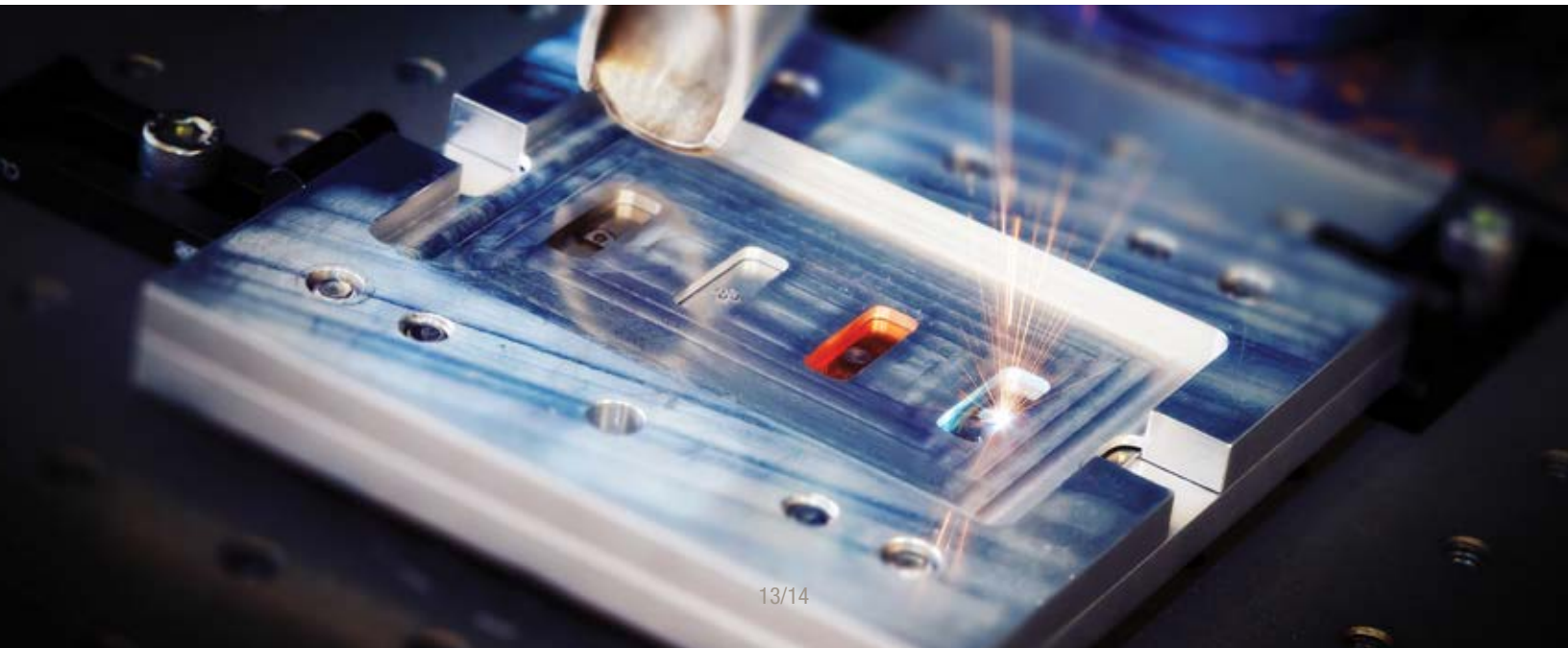



AMADA WELD TECH

Your Global Partner

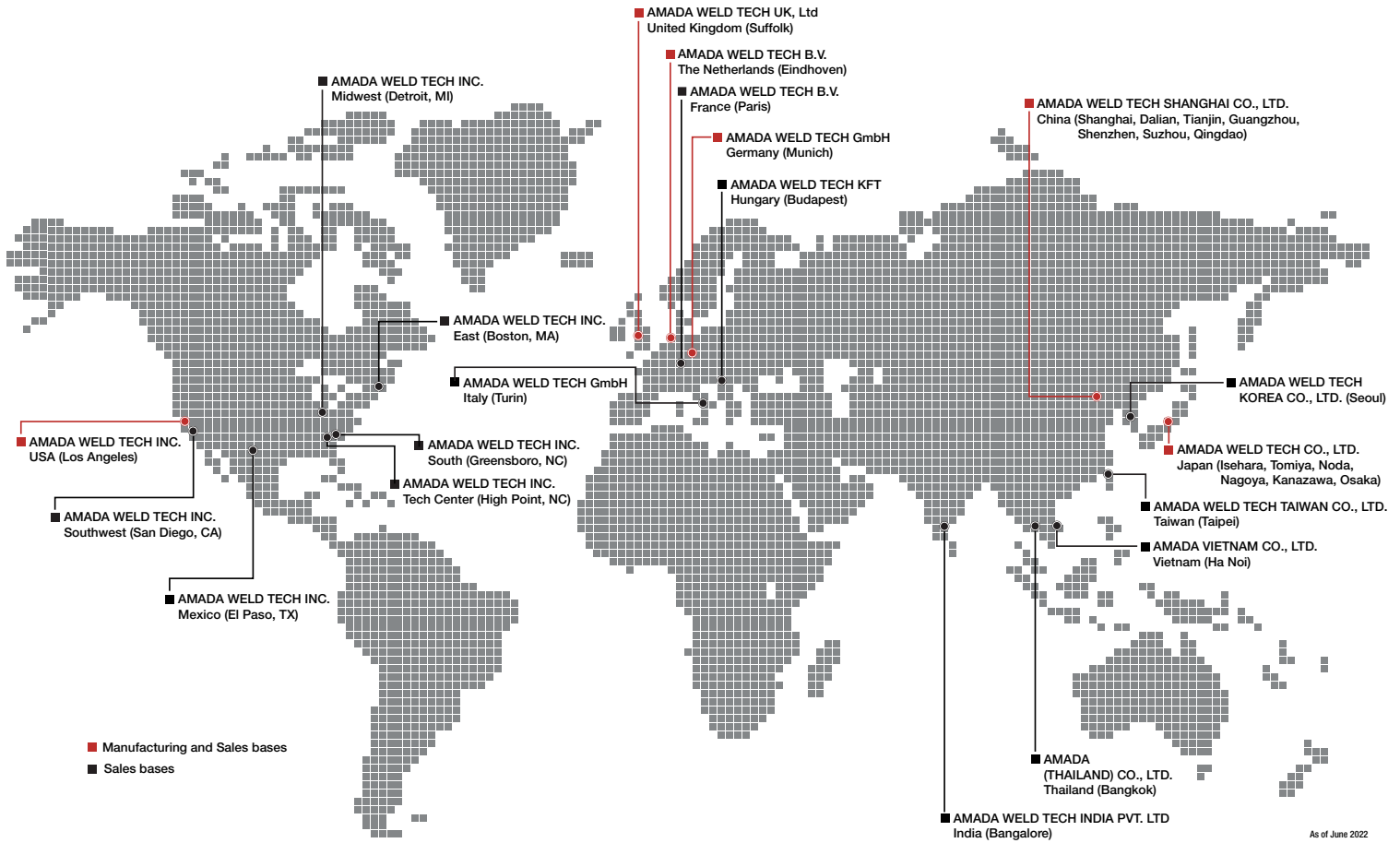

As of June 2022



AMADA WELD TECH INC.

USA

1820 S. Myrtle Ave. • Monrovia, CA 91016 US
 T: (626) 303-5676
info@amadaweldtech.com • www.amadaweldtech.com
 ISO 9001 Certified Company • 24/7 Repair Service: 1-866-751-7378

AMERICAS

AMADA WELD TECH (Eastern Technical Center)
 High Point, North Carolina
 T: (941) 544-5762
southsales@amadaweldtech.com

AMADA WELD TECH (Midwest Technical Center)
 Detroit, Michigan
 T: (248) 313-3078
midwestsales@amadaweldtech.com

AMADA WELD TECH (Mexico Office)
 El Paso, Texas
 T: (915) 881-8765
mxsales@amadaweldtech.com

EUROPE
AMADA WELD TECH GmbH
 Munich, Germany
 T: +49-89-839403-0
infode@amadaweldtech.eu

ASIA

AMADA WELD TECH CO., LTD.
 Isehara, Japan
 T: +81-4-7125-6177
sales@miyachi.com

AMADA WELD TECH SHANGHAI CO., LTD.
 Shanghai, China
 T: +86-21-6448-6000
sylli@amadaweldtech.com.cn
zqzhang@amadaweldtech.com.cn

AMADA WELD TECH KOREA CO., LTD.
 Seoul, Korea
 T: +82-31-8015-6810
sales@amadaweldtech.co.kr

AMADA WELD TECH TAIWAN CO., LTD.
 Taipei, Taiwan
 T: +886-2-2585-0161

AMADA (THAILAND) CO., LTD.
 Bangkok, Thailand
 T: +66-2170-5900
info@amada.co.th

AMADA VIETNAM CO., LTD.
 Ha Noi, Vietnam
 T: +84-4-6261-4583

AMADA WELD TECH INDIA PVT., LTD.
 Bangalore, India
 T: +91-80-4092-1749
info@miyachiindia.com

Specifications subject to change without notice. Copyright© 2022 AMADA WELD TECH INC. The material contained herein cannot be reproduced or used in any other way without the express written permission of AMADA WELD TECH INC. All rights reserved.

follow us on:

